

METHODOLOGY FOR RISK ASSESSMENT OF PART LOAD RESONANCE IN FRANCIS TURBINE POWER PLANT

C. NICOLET¹, J.-J. HEROU², B. GREIVELDINGER¹, P. ALLENBACH³,
J.-J. SIMOND³, F. AVELLAN¹

¹EPFL – Ecole polytechnique fédérale de Lausanne, christophe.nicolet@epfl.ch
Laboratory for Hydraulic Machines francois.avellan@epfl.ch

²EDF – Electricité de France, Centre d'Ingénierie jean-jacques.herou@edf.fr
Hydraulique

³EPFL – Ecole polytechnique fédérale de Lausanne, philippe.allenbach@epfl.ch
Laboratory of Electrical Machines jean-jacques.simond@epfl.ch

ABSTRACT

At low flow rate operation, Francis turbines feature a cavitating vortex rope in the draft tube resulting from the swirling flow of the runner outlet. The unsteady pressure field related to the precession of the vortex rope induces plane wave propagating in the entire hydraulic system. The frequency of the vortex rope precession being comprised between 0.2 and 0.4 times the turbine rotational speed, there is a risk of resonance between the hydraulic circuit, the synchronous machine and the turbine itself acting as excitation source. This paper presents a systematic methodology for the assessment of the resonance risk for a given Francis turbine power plant. The test case investigated is a 1GW 4 Francis turbines power plant. The methodology is based on a transient simulation of the dynamic behavior of the whole power plant considering a 1D model of the hydraulic installation, comprising gallery, surge chamber, penstock, Francis turbine but also mechanical masses, synchronous machines, transformer, grid model, speed and voltage regulators. A stochastic excitation having energy uniformly distributed in the frequency range of interest is taken into account in the draft tube. As the vortex rope volume has a strong influence on the natural frequencies of the hydraulic system, the wave speed in the draft tube is considered as a parameter for the investigation. The transient simulation points out the key excitation frequencies and the draft tube wave speed producing resonance between the vortex rope excitation and the circuit and provide a good evaluation of the impact on power quality. The comparison with scale model tests results allows resonance risk assessment in the early stage of project pre-study.

INTRODUCTION

Nowadays hydroelectric power plants are increasingly subject to off-design operation in order to follow the demand. In this context, Francis turbine power plants operating at part load may present instabilities in terms of pressure, discharge, rotational speed and torque. These phenomena are strongly linked to the flow structure at the runner outlet inducing a vortex core precession in the draft tube. This leads to hydrodynamic instabilities (Jacob, [5]). The decrease of the tailrace pressure level makes the vortex core visible as a gaseous vortex rope. The volume of the gaseous vortex rope is dependent of the cavitation number σ and affects the parameters characterizing the hydro-acoustic behavior of the entire power plant. As a result, natural frequencies of the hydraulic system decrease with the cavitation number (Tadel [16]). In addition, for a given cavitation number σ , the volume of the vortex rope changes with the discharge rate (Jacob, [5]), thus the natural frequencies are also dependent on the turbine discharge, i.e. the operating point. Therefore, the risk of an interaction between the excitation sources such as vortex rope precession and the natural frequencies resulting in resonance effects, called draft tube surge, is dependant on the cavitation number, but also on the operating point. Such resonance may result in unacceptable pressure pulsation or electrical power swing, (Rheingans [13], Tadel [16]).

In order to assess resonance risks on prototypes, pressure fluctuation measurements field are carried out during scale model tests to identify experimentally the pressure excitations sources and the vortex rope compliance [2]. Then, the pressure fluctuations due to non uniform pressure field at the runner outlet [9], [10], can be decomposed in two parts as proposed by Angelico [1]; (1) a rotating part, due to vortex rotation, and (2) a synchronous pulsating part resulting from the spatial perturbation of the rotating part. The pressure excitation source related to the synchronous pulsating part can be extracted using the procedure described by Dörfler, [2]. It is then possible to deduce the resulting mechanical torque pulsation in the frequency domain, using an appropriate one dimensional model of the full hydraulic system based on impedance method, including the model of the vortex rope and the turbine itself, [3], [16], [4]. However, obtaining the induced electrical power pulsations, requires to include the linearized model of the synchronous machine, the voltage regulator, transformer, etc, which is very challenging.

This paper presents a methodology using a time domain simulation for the determination of the part load resonance risk and its impact on the electrical power pulsations of a Francis turbine power plant. Therefore, the case of an hydroelectric power plant with 4x250MW Francis turbine is investigated, see Figure 1. First, the numerical model based on an electrical equivalent is presented. The model of the draft tube, taking into account the vortex rope volume and the pressure excitation source is described. Then a simplified model of the piping is derived for

analyzing qualitatively the resonance risk of the power plant. Finally, a time domain simulation of the dynamic behavior of the whole hydroelectric power plant is performed with SIMSEN, in order to deduce the transfer function between the pressure excitation in the draft tube and the synchronous machine electrical active power. Influence of the draft tube wave speed, i.e. vortex rope volume, is presented.

4x250MW FRANCIS TURBINE HYDROELECTRIC POWER PLANT

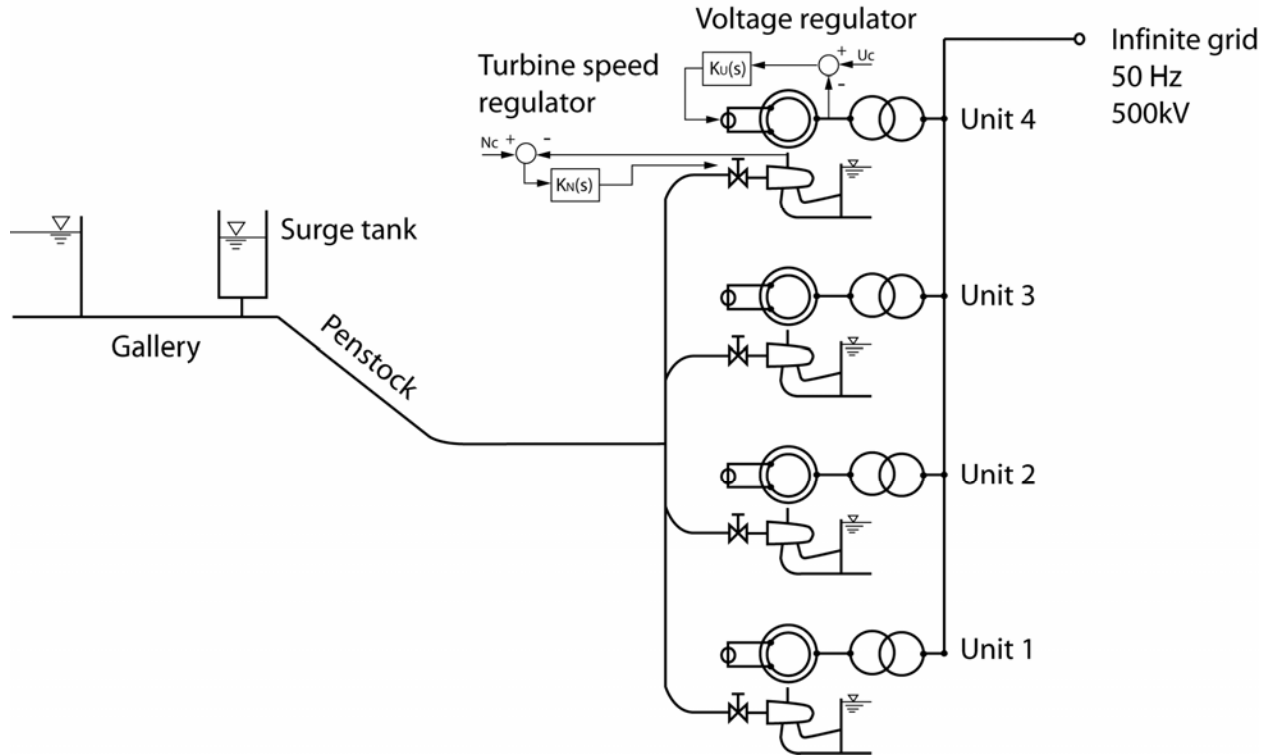

Figure 1 Hydraulic power plant layout.

MODELING OF THE HYDROELECTRIC POWER PLANT

Hydraulic system modeling

By assuming uniform pressure and velocity distributions in the cross section and neglecting the convective terms, the one-dimensional momentum and continuity balances for an elementary pipe filled with water of length dx , cross section A and wave speed a , see Figure 2, yields to the following set of hyperbolic partial differential equations [18]:

$$\begin{cases} \frac{\partial h}{\partial t} + \frac{a^2}{gA} \cdot \frac{\partial Q}{\partial x} = 0 \\ \frac{\partial h}{\partial x} + \frac{1}{gA} \cdot \frac{\partial Q}{\partial t} + \frac{\lambda|Q|}{2gDA^2} \cdot Q = 0 \end{cases} \quad (1)$$

The system (1) is solved using the Finite Difference Method with a 1st order centered scheme discretization in space and a scheme of Lax for the discharge variable. This approach leads to a system of ordinary differential equations that can be represented as a T-shaped equivalent

scheme [6], [11], as presented Figure 3. The RLC parameters of this equivalent scheme are given by:

$$R = \frac{\lambda \cdot |\bar{Q}| \cdot dx}{2 \cdot g \cdot D \cdot A^2} \quad L = \frac{dx}{g \cdot A} \quad C = \frac{g \cdot A \cdot dx}{a^2} \quad (2)$$

Where λ is the local loss coefficient. The hydraulic resistance R , the hydraulic inductance L , and the hydraulic capacitance C correspond respectively to energy losses, inertia and storage.

The model of a pipe of length L is made of a series of n_b elements based on the equivalent scheme of Figure 3. The system of equations relative to this model is set-up using Kirchoff laws. The model of the pipe, as well as the model of valve, surge tank, Francis turbine, etc, are implemented in the EPFL software SIMSEN, developed for the simulation of the dynamic behavior of hydroelectric power plants, [8], [15]. The time domain integration of the full system is achieved in SIMSEN by a Runge-Kutta 4th order procedure.

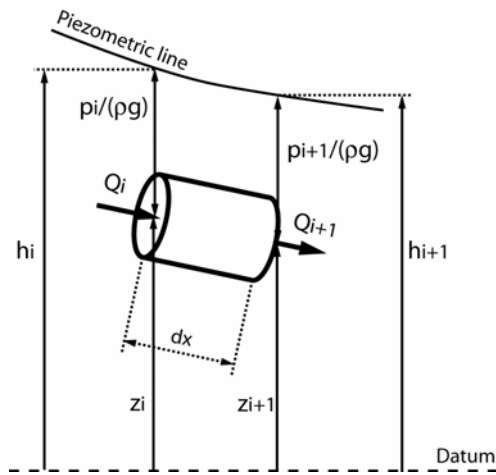

Figure 2 Elementary hydraulic pipe of length dx.

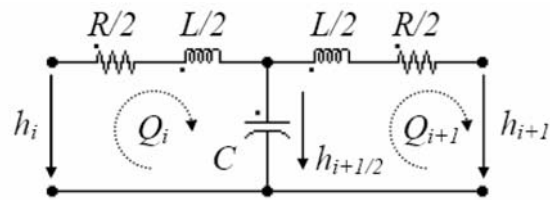

Figure 3 Equivalent circuit of an elementary pipe of length dx.

Draft tube model

For resonance risk assessment purposes, the Francis turbine draft tube can be properly modeled by a pressure source excitation in series with 2 pipes, as presented Figure 3, [7]. In this model, the excitation source can be determined from scale model testing, [2], or CFD computation, [14], while the pipe is modeled using one dimensional hydroacoustic model that requires knowing the following parameters:

- the length of the pipe; obtained from the geometry;
- the cross section; determined also from the geometry;
- the wave speed; to be calculated or measured;

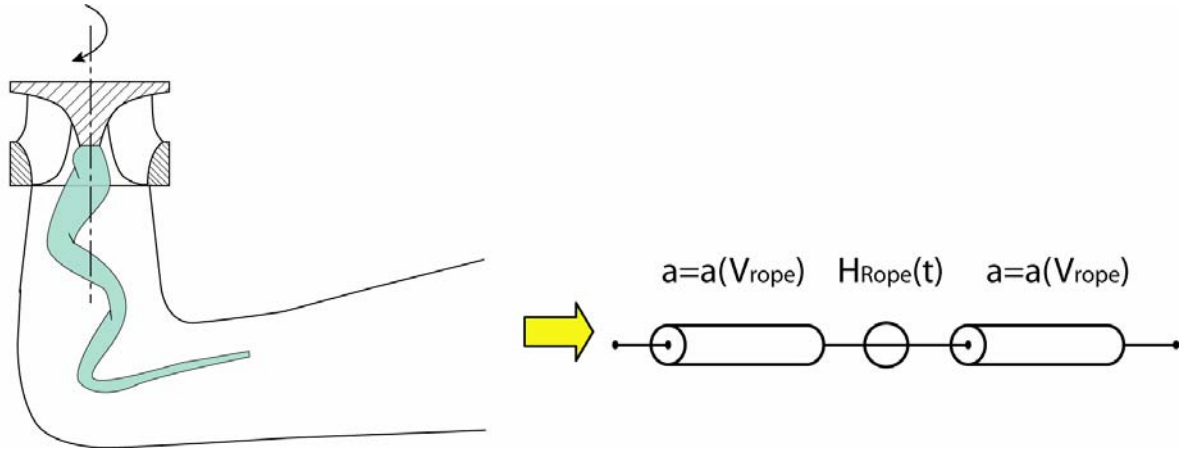

Figure 4 Modeling of the draft tube.

The geometrical parameters can be estimated by piecewise integration from draft tube inlet until the outlet. However, the determination of the wave speed is more challenging and is out of the scope of this paper; the draft tube wave speed in this investigation is taken as a parameter. Nevertheless, it is convenient to link the draft tube wave speed to an equivalent rope diameter, resembling the approach developed by Philibert and Couston, [12], in order to link the wave speed to a physical dimension.

Assuming a cross section of the draft tube with diameter D and with a rope diameter D_R , one can determine the gas volume fraction α of the cross section as follows:

$$\alpha = \frac{A_{Rope}}{A_{tot}} = \left(\frac{D_R}{D} \right)^2 \quad (3)$$

Where A_{rope} is the cross section of the rope and A_{tot} is the total draft tube cross section for a given curvilinear abscissa.

The wave speed in the liquid gas mixture is given by [17]:

$$a_m^2 = \frac{1}{\rho_m \cdot \left(\frac{\alpha}{\rho_g \cdot a_g^2} + \frac{(1-\alpha)}{\rho_L \cdot a_L^2} \right)} \quad (4)$$

The wave speed of the liquid gas mixture is represented as a function of the gas volume fraction, see Figure 5, and as function of the cavitation rope rated diameter by combining equations (3) and (4), see Figure 6. It is pointed out how the wave speed of the mixture is dropping to very low values with respect to the cavitation rope diameter. Cavitating rope diameter up to $D_R/D = 0.1$ are common in part load operation of Francis turbine, see Jacob [5]. For such rated diameter, the draft tube cross section wave speed would be below 100 m/s. However, it has to be noticed that this model assumes a cylindrical vortex rope with constant diameter, from draft tube inlet to outlet, whereas the real vortex rope is helicoidal and conical. Therefore, the presented approach is only useful to link the wave speed to a physical dimension. In addition, thermodynamic effects related to the cavitation phenomenon are neglected.

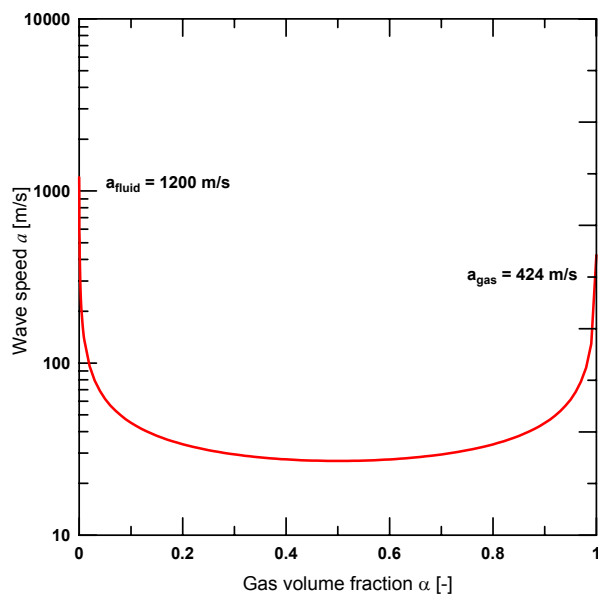

Figure 5 Wave speed in vapor/water mixture.

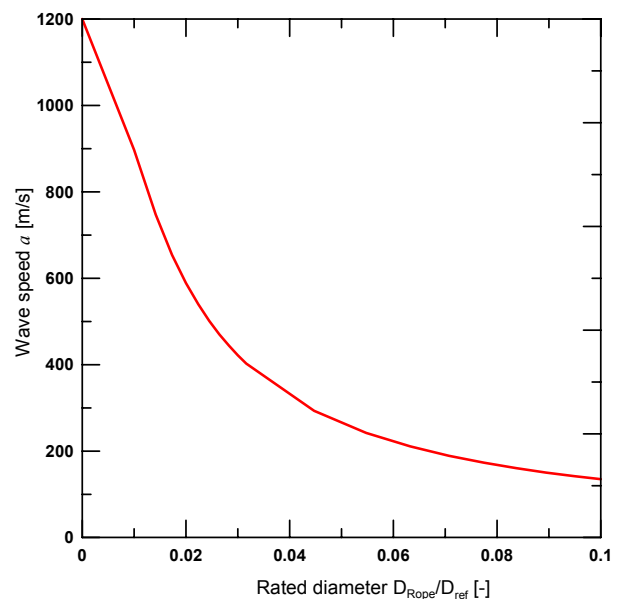

Figure 6 Wave speed as function of rated diameter.

Hydraulic power plant model

The layout of the SIMSEN model of the hydroelectric power plant of interest is presented Figure 8. The power plant is made of a 1'515 meters long gallery, a surge tank with variable section, a 1'388 meters long penstock and a manifold feeding 4x250 MW Francis turbines. The main parameters of the hydroelectric power plant are summarized Table 1.

Table 1 Hydraulic power plant characteristics.

Gallery	Length: 1'515 m Diameter: 8.8 m Wave speed: 1'000 m/s
Surge tank	Mid tank section: 133 m ²
Penstock	Length: 1'388 m Diameter: 8.8 / 7.15 m Wave speed: 1200 m/s
Francis turbine	Rated mechanical power: P _R = 250 MW Rated speed: N _R = 333.3 rpm Rated discharge: Q _R = 75 m ³ /s Rated head: H _R = 350 m Specific speed: v = 0.226 Reference diameter: D _{ref} = 2.82 m Inertia : J _t = 1.7·10 ⁵ kg·m ²
Generator	Rated apparent power: S _n = 270 MVA Rated phase to phase voltage: V _n = 18KV Frequency: f = 50 Hz Number of pairs of poles: p = 9 Stator windings: Y Inertia: J _G = 1.54·10 ⁶ kg·m ²
Coupling shaft	Stiffness: K = 3.62·10 ⁸ Nm/rad Viscous damping: μ = 6.7·10 ³ Nms/rad

The gallery and the penstock in the SIMSEN model are respectively discretized into 22 and 243 elements. The Francis turbine characteristics discharge and torque factors versus the speed factor are presented for different guide vane opening values y , see Figure 7. The discharge, torque and speed factors are defined as follows:

$$N_{11} = \frac{N \cdot D_{ref}}{\sqrt{H}} \quad ; \quad Q_{11} = \frac{Q}{D_{ref}^2 \cdot \sqrt{H}} \quad ; \quad T_{11} = \frac{T}{D_{ref}^3 \cdot H} \quad (5)$$

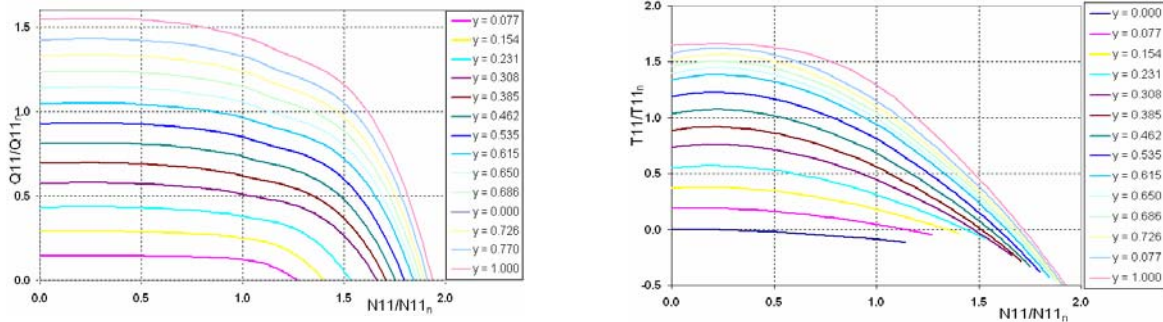

Figure 7 Turbine characteristics $Q_{11}=Q_{11}(N_{11})$, left, and $T_{11}=T_{11}(N_{11})$, right, for different GVO opening y .

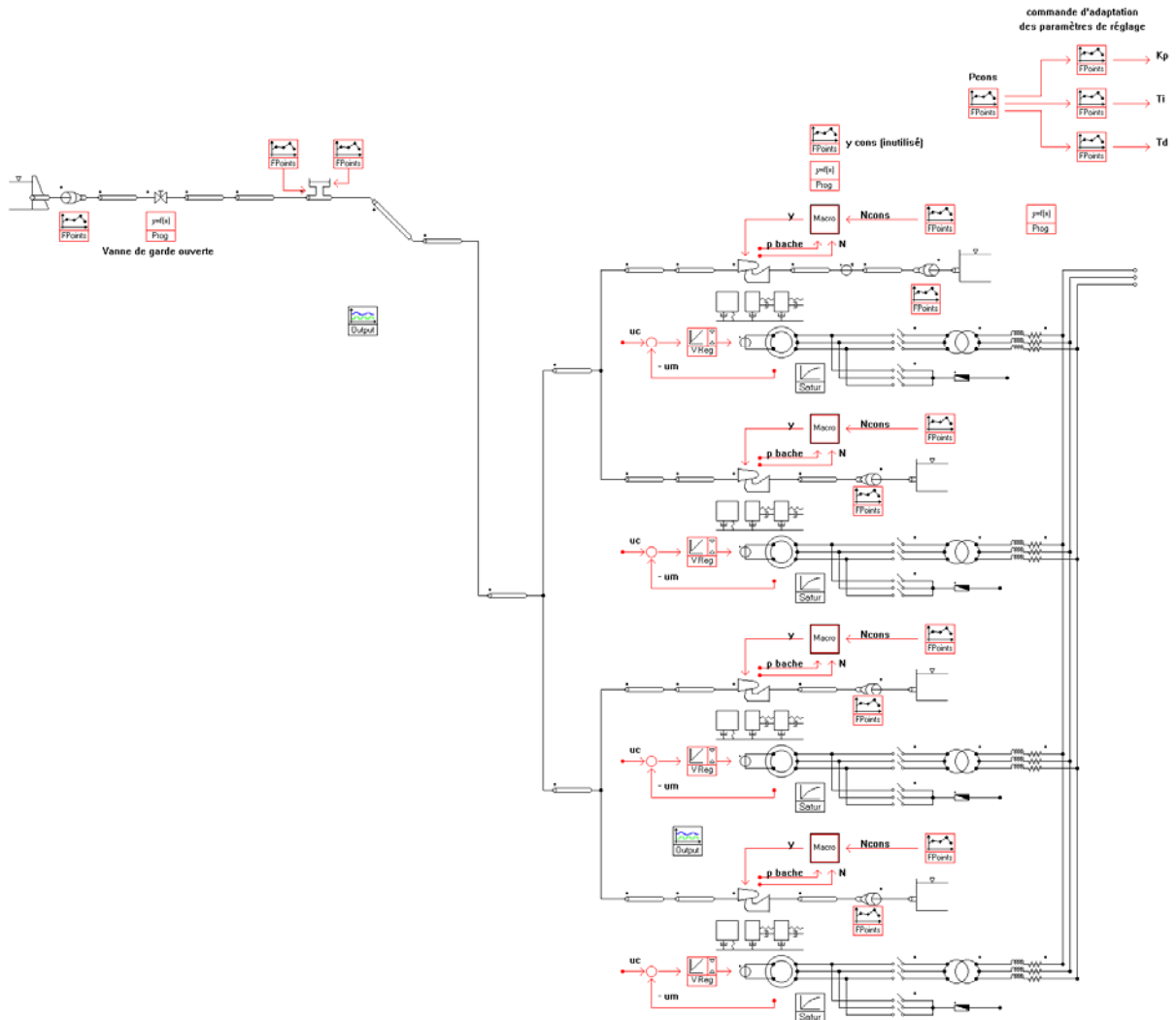

Figure 8 Full SIMSEN model of the hydroelectric power plant.

RESONANCE RISK ASSESSMENT

Simplified analysis

The main natural frequencies of the piping system feeding the 4 turbines of the power plant can be estimated through the analysis of the natural frequencies of an equivalent pipe of the adduction system. Because of the longitudinal symmetry of the piping, a simplified model of the piping can be used. The simplified model, presented Figure 9, comprises 2 pipes: the adduction, and the draft tube. Thus the influence of the draft tube wave speed change with natural frequencies can be qualitatively investigated.

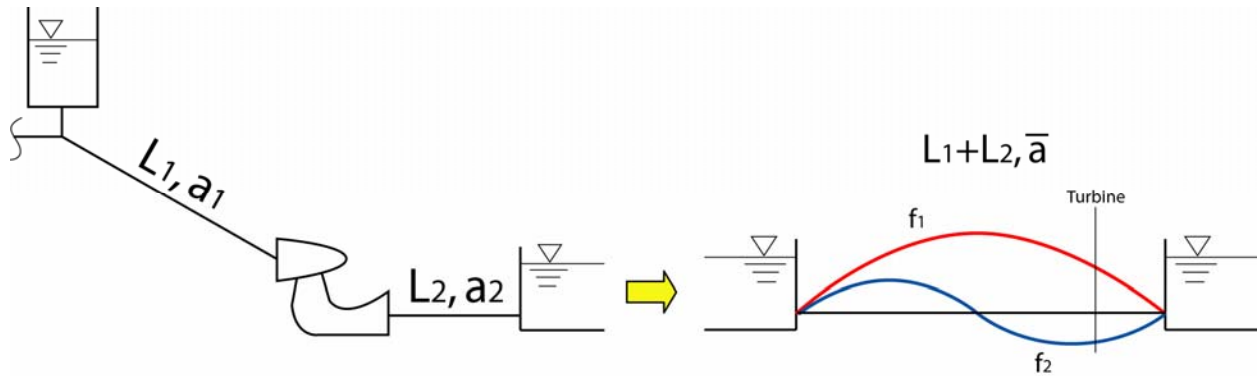

Figure 9 Simplified piping model.

Table 2 Main characteristics of the simplified model Figure 9.

Description	Length L [m]	Wave speed a [m/s]
Adduction	1478	1146
Draft tube	30	1200, 200, 100, 50

The equivalent wave speed of the piping system is given by:

$$\bar{a} = \frac{L_1 + L_2}{\frac{L_1}{a_1} + \frac{L_2}{a_2}} \quad (6)$$

Considering both upstream and downstream free surface boundary conditions of the piping, the equivalent wave length of the i^{th} natural mode of the piping is given by:

$$\lambda_i = \frac{2}{i} \cdot (L_1 + L_2) \quad (7)$$

The corresponding natural frequency is therefore given by [18]:

$$f_i = \frac{\bar{a}}{\lambda_i} = \frac{i}{2 \cdot \left(\frac{L_1}{a_1} + \frac{L_2}{a_2} \right)} \quad (8)$$

The 10 first natural frequencies of the simplified piping of Figure 9 are computed for wave speeds in the draft tube ranging from $a = 1200$ m/s to $a = 50$ m/s. The length and wave speed of the simplified model are summarized Table 2.

The natural frequencies obtained for different rated cavitating rope diameters are presented Figure 10. As expected, the natural frequencies of the piping system are decreasing with respect to the wave speed. The natural frequency of the generator $f_{ogen} = 1.21$ Hz is also represented Figure 10. The graph evidences an intersection between the 4th piping natural frequency and the generator natural frequency for a draft tube wave speed of 77 m/s. This intersection is in the range where pressure pulsation induced by cavitating vortex rope extending from 0.2 to 0.4 times the turbine rotating frequency, f_n , are expected. This situation corresponds to one of the worst case for the power plant, because there is a coincidence of the piping natural frequencies and the generator natural frequency. However, this requires that the pressure pulsation induced by the draft tube flow matches to this frequency. In addition, the influence on the electrical power fluctuation is strongly dependant on the turbine position, relatively to the pressure mode shape corresponding to this 4th natural frequency. Nevertheless, this simplified model shows the interest of investigating carefully the resonance risk for the power plant of interest.

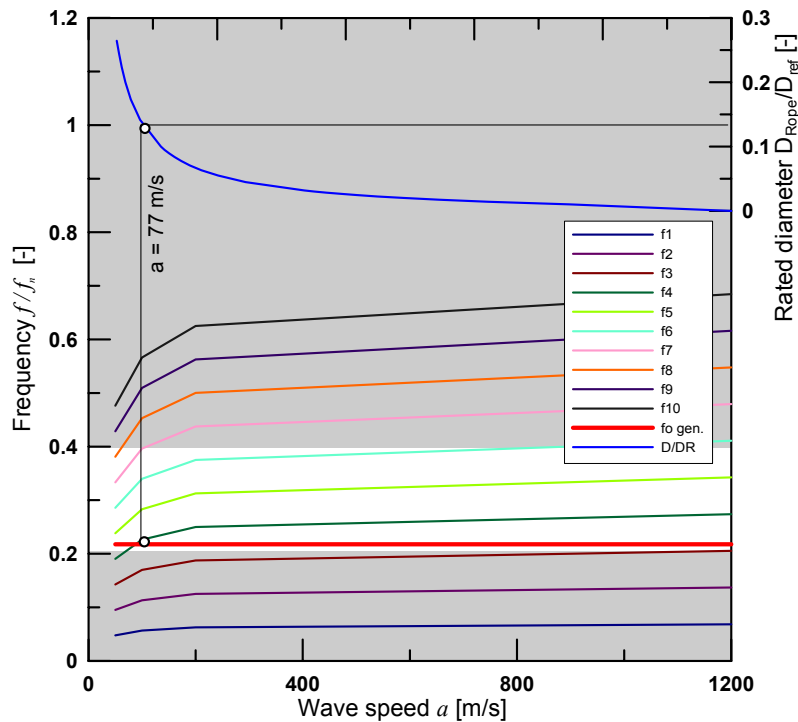

Figure 10 Power plant natural frequencies estimation with simplified model ($f_n = 5.555$ Hz).

Frequency domain analysis

Generator natural frequency

The transfer function of the synchronous machine between the mechanical and electromagnetic torques is calculated to deduce the generator natural frequency. Therefore, only the electrical part of the simulation model is taken into account. A Pseudo Random Binary Sequence – PRBS– [7] is used to generate a mechanical torque white noise excitation, see Figure 11. The transfer function between the mechanical and electromagnetic torques is calculated and

represented Figure 12. This transfer function evidences the generator natural frequency at 1.21 Hz (0.217 fn) and mechanical masses natural frequency of 7.5 Hz (1.35 fn). The generator natural frequency is in the range of 0.2 to 0.4 fn and represents thus a resonance risk.

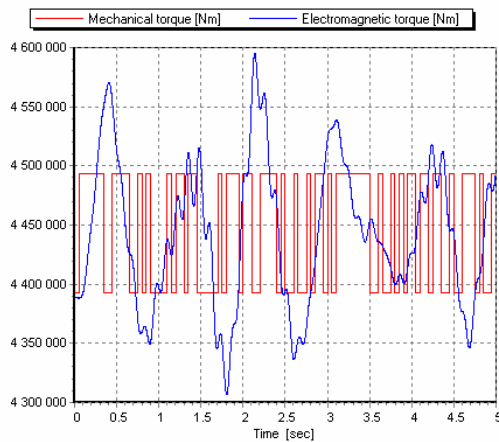

Figure 11 PRBS mechanical torque excitation of the generator.

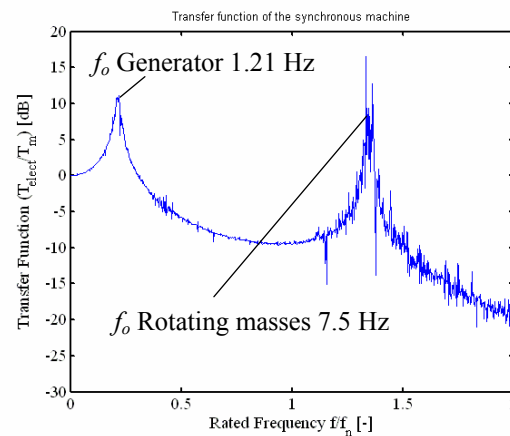

Figure 12 Generator transfer function between mechanical and electromagnetic torque.

Piping resonance

The full hydroelectric simulation model is taken into account to calculate the transfer function between the draft tube pressure source excitation and the electromagnetic torque. A PRBS draft tube pressure source excitation at the draft tube of the turbine of Unit 4 is considered for the time domain simulation. For this simulation the turbine speed governor is removed and guide vane are kept with constant opening of 40%, corresponding to 65% of the nominal discharge.

The resulting pressure oscillations in the piping system are represented as a waterfall diagram for draft tube wave speed of: 200, 100, 77, and 50 m/s in Figure 13. The pressure pulsations are represented as a function of the x coordinate starting from the surge tank (node 1) and extending along the piping until the Unit4 downstream tank (node 289) and the rated frequency f/f_n . Not all piping natural frequencies are excited; this is due to the draft tube excitation source relative position in the piping. It is pointed out how the natural frequencies are dropping with respect to the draft tube wave speed. In addition, because the wave speed of the draft tube affects the pressure node and maxima location, this is not the same mode shapes that are excited for the different wave speeds. Regarding the frequency range of interest, 0.2 to 0.4 fn, it can be seen that the lower the draft tube wave speed, the higher number of natural frequencies in the frequency range of interest. Comparing these results with the simplified model it can be seen that the natural frequency at 77 m/s that was pointed out as critical is not excited by the draft tube pressure source and does not appear on the waterfall diagram, evidencing the limitation of such simplified models.

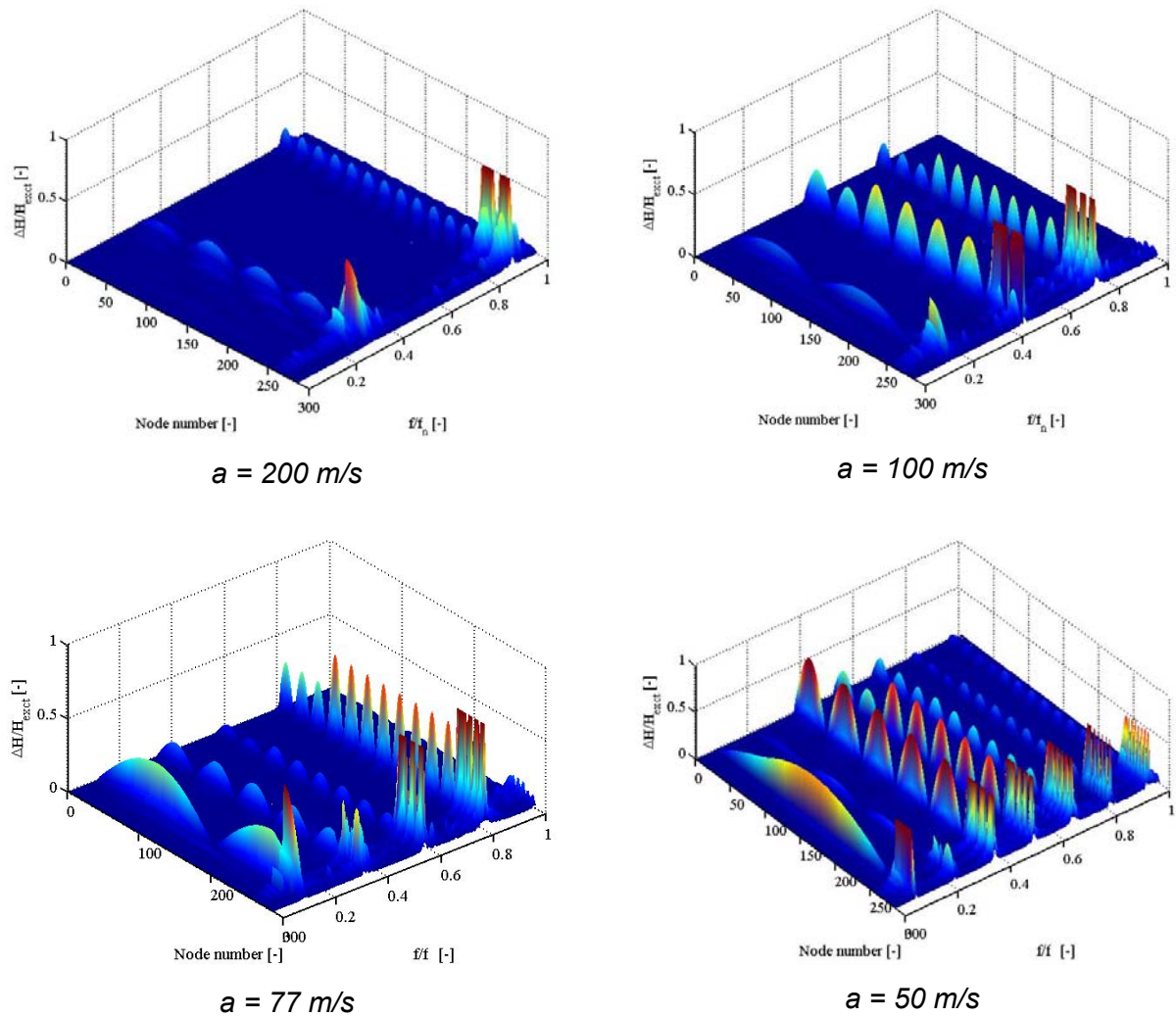

Figure 13 Piping pressure oscillations for different draft tube wave speed.

Hydroelectric resonance

The influence of the draft tube excitation on the mechanical and electromagnetic torques is evaluated by calculating the transfer function between the draft tube pressure excitation and both mechanical and electromagnetic torques; both transfer functions are respectively presented Figure 14 and Figure 15. Mechanical torque oscillations occur for all excited piping mode shapes. This is not always the case, because torque pulsation requires that the head of the turbine, i.e. the difference of head between the inlet and the outlet, is pulsating, and that is dependant on the position of the turbine relatively to the pressure mode shape. Moreover, the electromagnetic torque pulsations are strongly affected by the generator natural frequency. A clear amplification effect between the mechanical and the electromagnetic torque appears for a draft tube wave speed of 50 m/s, where there is coincidence of a piping natural frequency and generator natural frequency. Thus, the worst conditions for the power plant is when the draft tube excitation is at 0.217 f_n with a draft tube wave speed of 50 m/s. However, for this draft tube

wave speed, electromagnetic torque pulsations are expected in almost the whole vortex rope frequency range due to the presence of 2 piping natural frequencies in this range, i.e. $0.217 f_n$ and $0.37 f_n$.

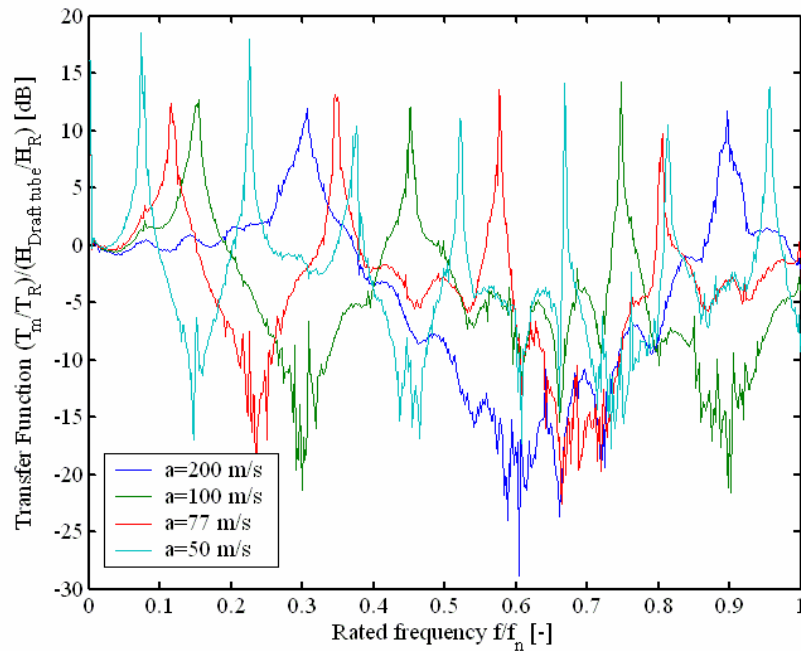

Figure 14 Transfer function between the draft tube pressure source and the turbine mechanical torque.

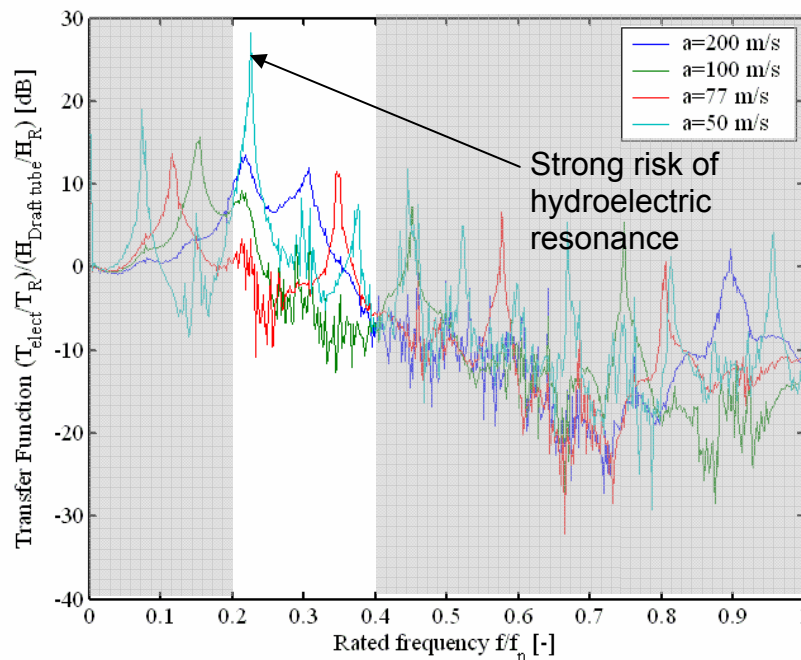

Figure 15 Transfer function between the draft tube pressure source and the generator electromagnetic torque.

Confrontation with experimental data

Once the piping resonance frequency and mode shape as well as the generators resonance frequency are known for different wave speeds, these results have to be compared with

measurements of draft tube pressure pulsations performed during scale model tests in order to evaluate the risk of resonance. The model tests, see Figure 16, provide:

- the vortex rope pressure pulsations frequencies and amplitudes [2];
- the vortex rope diameter by means of photography, or the vortex rope compliance by the method described by Dörfler [2]

Finally, the possible resonances with the piping system and with the generator are pointed out from cross checks between parametric simulations results and the model tests data providing the set of resonant conditions. The amplitudes of pressure oscillations in the system and generator power swing can be estimated from the time domain simulation with the set of resonant parameters. The overall methodology is summarized in the synoptic scheme of Figure 17.

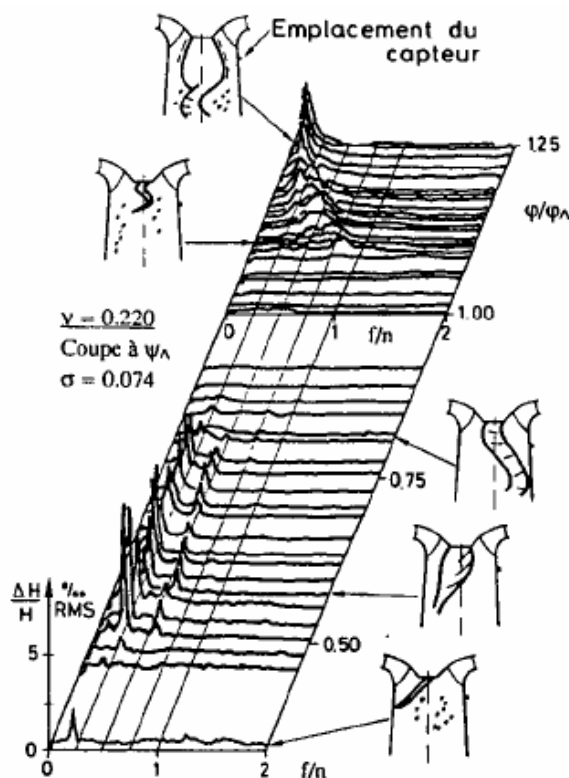

Figure 16 Waterfall diagram and vortex rope shape observations from model tests, [5].

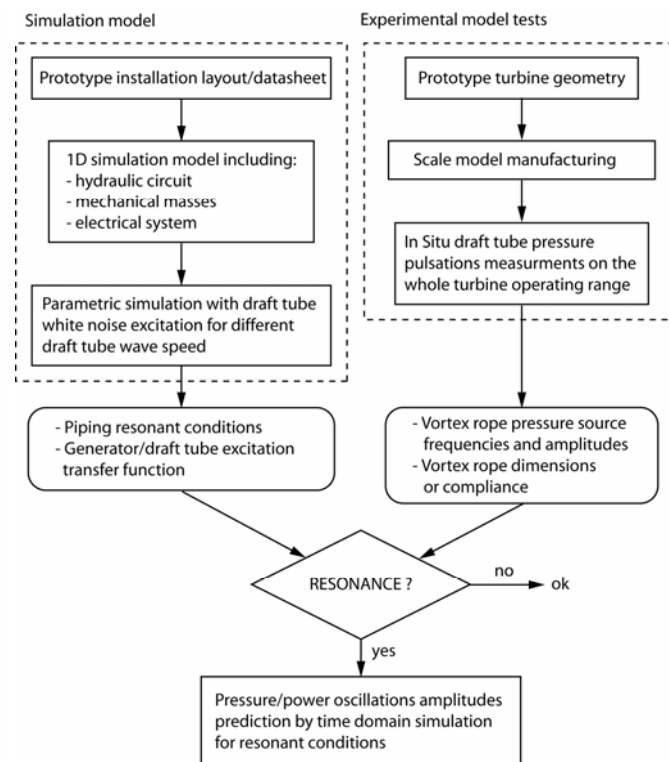
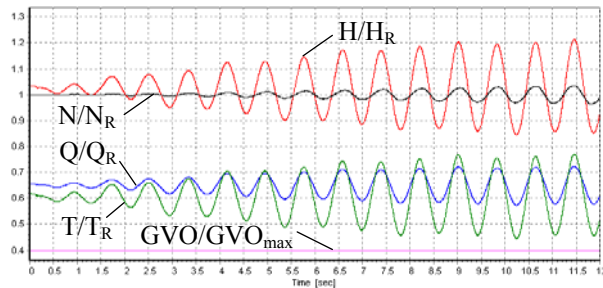

Figure 17 Synoptic scheme of the overall methodology.

Amplitude prediction by time domain analysis

In order to illustrate the consequence of a resonance in the hydroelectric power plant studied, a time domain simulation is performed with draft tube sinusoidal excitation at $f/n = 0.217$ with amplitude of $\Delta H = 10mWC$ and a draft tube wave speed of 50 m/s (the worst case for this power plant). For this simulation the turbine speed governor is neglected. The simulations results are respectively presented for the turbine variables, Figure 18 a) and the generator variable Figure

18 b). The time evolution of the head at the Unit 4 spiral casing and draft tube are presented Figure 18 c). The turbine head is strongly pulsating because of the difference of head between the inlet and the outlet of Unit 4 turbine. Consequently, the mechanical torque is pulsating at the vortex rope frequency. These mechanical torque pulsations are amplified by a factor 10 by the generator. Such situation leads to catastrophic pressure and torque pulsations in the hydroelectric power plant.



a)

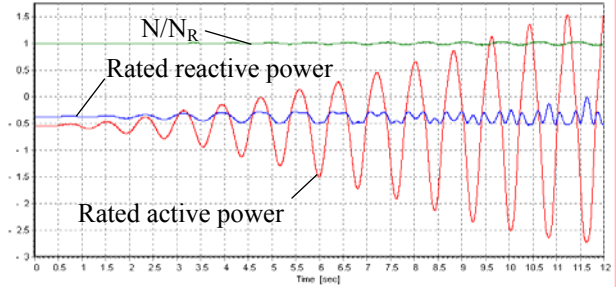

b)

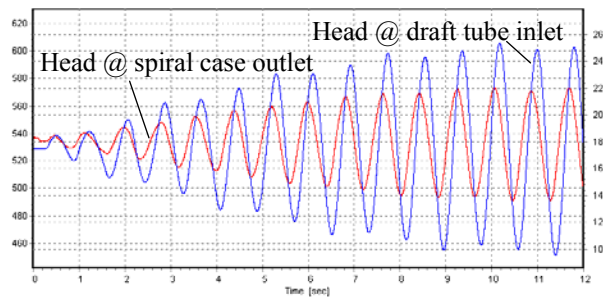

c)

Figure 18 Time evolution of the turbine variables a), generator variables b) and head at the turbine inlet/outlet c) of Unit 4 resulting from full hydroelectric resonance.

CONCLUSION

This paper presents a methodology for the assessment of the risk of resonance of a hydroelectric power plant operating at part load and subject to draft tube pressure pulsations. This method is based on a time domain simulation of the dynamic behavior of the whole hydroelectric power plant considering a white noise draft tube pressure excitation. This simulation is done for different draft tube wave speeds. The simulation results reveal the piping natural frequencies that are excited by the draft tube pressure source. In addition, the transfer function between the draft tube pressure source and the generator electromagnetic torque points out the risk of electrical power swing. However, the risk can be really evaluated only knowing the pressure excitations and the draft tube wave speed. If the first one can be obtained from scaled model testing, the latter has to be estimated, either experimentally from vortex rope photography, or in the future, by CFD.

Nevertheless, the presented methodology is a helpful tool for predicting the risks of resonance at the early stages of pre-design or as a help for on site diagnostic purposes.

NOMENCLATURE

A	Cross section (m ²)	a	Wave speed (m/s)
C	Hydraulic capacitance (m ²)	f	Frequency (Hz)
D	Pipe diameter (m)	g	Gravity(m/s ²)
E	Specific energy $E = gH$ (J/Kg)	h	Piezometric head $h = z + p/(\rho \cdot g)$ (m)
GVO	Guide vane opening (-)	p	Pressure (Pa)
H	Head (m)	t	Time (s)
L	Hydraulic inductance (s ² /m ²)	x	Abscissa (m)
N	Rotational speed (rpm)	α	Gas volume fraction (-)
Q	Discharge (m ³ /s)	λ	Friction loss coefficient (-)
R	Hydraulic resistance (s/m ²)	v	Turbine specific speed
T	Torque (Nm)		$v = \omega(Q/\pi)^{1/2}/(2E)^{3/4}$ (-)
Z	Elevation (m)		

ACKNOWLEDGEMENT

For this paper, the authors took advantages of the development of the SIMSEN hydraulic extension, developed in collaboration with the EPFL Laboratory for Electrical Machines under the following contract awards: CTI No 5750.1 EBS, PSEL No 215 Scapin, EDF-CIH, HMD 420.210.3459.

REFERENCES

- [1] Angelico, F. M. G., Muciaccia, F. F., Rossi, G., "Part load behavior of a turbine: a study on a complete model of a hydraulic power plant," Proceedings of the IAHR Symposium, paper 17, Montreal, 1986.
- [2] Dörfler, P., "System dynamics of the Francis turbine half load surge." IAHR Symposium, Amsterdam, paper 39, 1982.
- [3] Dörfler, P., "Modèle mathématique des oscillations excitées à charge partielle par la torche de cavitation dans les turbines Francis", Bulletin Escher Wyss 1/2, 1980, pp. 101-106.
- [4] Fritsch, A., Maria, D., "Comportement dynamique d'une turbine Francis à charge partielle: comparaison modèle-prototype", La Houille Blanche, N°3/4, 1988, pp. 273-280.
- [5] Jacob, T., "Evaluation sur modèle réduit et prédiction de la stabilité de fonctionnement des turbines Francis." Thesis. Lausanne: EPFL, 1993.
- [6] Jaeger, R. C., "Fluid transients in hydro-electric engineering practice ".Glasgow: Blackie, 1977.

- [7] Nicolet, C., Arpe, J., Avellan, F., "Identification and modeling of pressure fluctuations of a Francis turbine scale model at part load operation", 22nd Symposium of IAHR, Sweden, Stockholm, paper A7-1, 2004.
- [8] Nicolet, C., Avellan, F., Allenbach, P., Sapin, A., Simond, J.-J., Kvicinsky, S., Crahan, M., "Simulation of Transient Phenomena in Francis Turbine Power Plants : Hydroelectric Interaction ". Proceedings of Waterpower XIII, Advancing Technology for Sustainable Energy, Buffalo, N.Y., USA, July 2003.
- [9] Nishi, M., "Surging characteristics of conical and elbow type draft tubes." Proceeding of the 12th IAHR Symposium, Stirling, p272-283, 1984.
- [10] Palde, U. J., "Model and prototype turbine draft tube surge analysis by the swirl momentum method", Proc. 7th Symposium IAHR, Hydraulic Machinery and System, 1974, paper III.
- [11] Paynter, H. M., "Surge and water hammer problems". Transaction of ASCE, vol. 146, p 962-1009, 1953.
- [12] Philibert, R., Couston, M., "Francis turbine at part load : Matrix simulating the gaseous rope". In Proc. Of the 19th IAHR Symposium, Singapore, 1998, vol. 1, pp. 441-453.
- [13] Rheingans, W. J., "Power swing in hydroelectric power plants." Transaction, American Society of Mechanical Engineers, Vol. 62, pp 171-184, 1940.
- [14] Ruprecht, A., Helmrich, T., "Simulation of the water hammer in hydro power plant caused by draft tube surge", Proc. Of 4th ASME JSME Conf., Hawaii, USA, 2003, paper FEDSM2003-45249.
- [15] Sapin, A., "Logiciel modulaire pour la simulation et l'étude des systèmes d'entraînement et des réseaux électriques", Thesis EPFL n° 1346, 1995.
- [16] Tadel, J., Maria, D., "Analysis of dynamic behavior of a hydroelectric installation with Francis turbine", Proc. 5th Int. Conf on Pressure Surges, Hannover, Germany, 1986, pp.43-52.
- [17] Wallis, G. B., "One-dimensional two-phase flow", Mc Graw-Hill, New York, 1969.
- [18] Wylie, E. B. & Streeter, V.L., "Fluid transients in systems". Prentice Hall, Englewood Cliffs, N.J, 1993.